

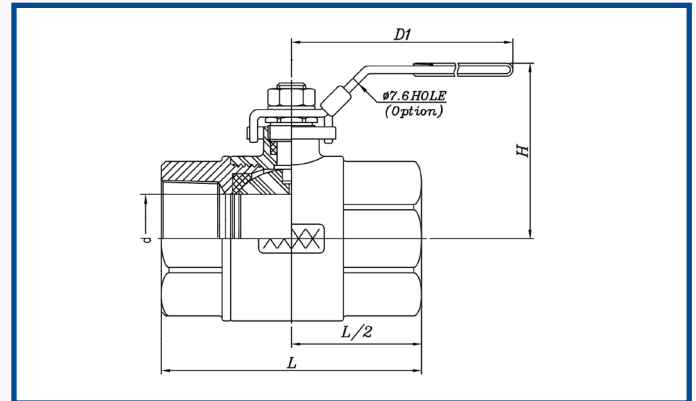

CP202L

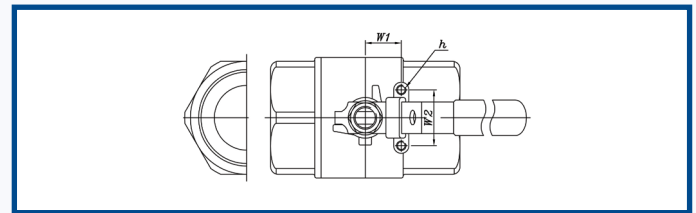

MATERIALS	
Ball:	Stainless Steel ASTM-CF8M
Body:	Stainless Steel ASTM-CF8M
Cap:	Stainless Steel ASTM-CF8M
Gland Washer:	Stainless Steel 304
Handle:	Stainless Steel 304
Seats:	RPTFE
Spring Water:	Stainless Steel 304
Stem Seal:	PTFE
Stem:	Stainless Steel 316
Thrust Washer:	PTFE
Washer:	Stainless Steel 304

CONNECTIONS
BSP Parallel: ISO228 Class A (Equivalent to DIN259)
NPT: National Pipe Thread (ANSI B1.20.1)

SIZE	1/4"	3/8"	1/2"	3/4"	1"	1 1/4"	1 1/2"	2"	2 1/2"	3"	4"	5"
d (mm)	11.0	12.5	15.0	20.0	25.0	32.0	40.0	50.8				
L (mm)	59.5	59.5	64.5	77.0	90.5	99.5	118.0	136.5				
H (mm)	57.0	57.0	57.6	68.5	72.7	87.7	93.0	104.3				
D1 (mm)	103.0	103.0	103.0	127.0	127.0	156.0	193.0	193.0				
W1 (mm)	12.7	12.7	12.7	22.4	22.4	25.4	25.4	25.4				
h	M5 P0.8	M5 P0.8	M5 P0.8	M6 P1.0	M6 P1.0	M6 P1.0	M6 P1.0	M6 P1.0				
W2 (mm)	28.5	28.5	28.5	35.0	35.0	38.1	38.1	38.1				
Rating	PN150	PN150	PN150	PN150	PN150	PN100	PN100	PN100				
Rating (psi)	2000	2000	2000	2000	2000	1500	1500	1500				
Weight (kg)	0.30	0.25	0.35	0.55	0.85	1.40	2.10	3.15				

Pressure and temperature ratings are minimum and maximum values only and actual performance will be dependant upon application.

All images on this page are for guidance only. E&OE. We reserve the right to amend specifications, prices & products without prior notification